

Cyclepods Shelters 2012 VI

Improving cycling facilities

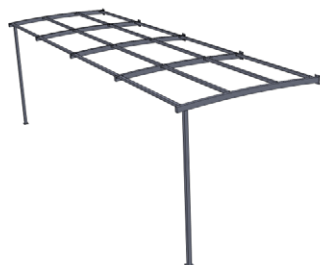
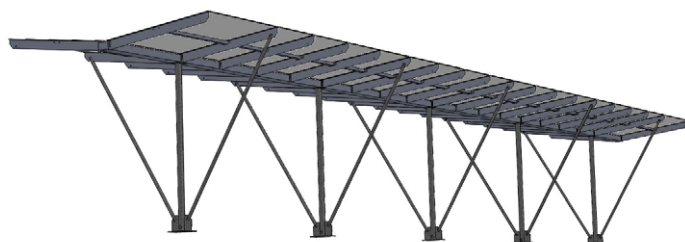
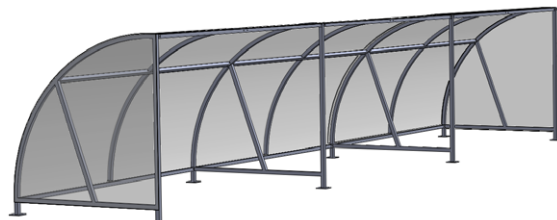
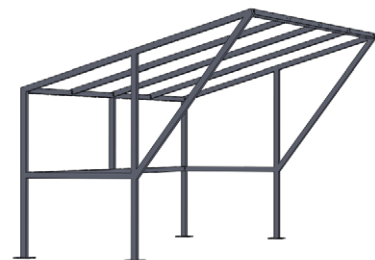

The first and only Carbon Neutral Cycle Storage company

Cyclepods Ltd | T - 0845 094 0490 | F - 0845 094 0151 | www.cyclepods.co.uk | info@cyclepods.co.uk



Cyclepods
Transforming bike storage

Contents

Improving cycling facilities



Table of Contents

Welcome	Page 3
Street Shelter One	Page 4
Street Shelter One Compound	Page 5
Street Shelter Two	Page 6
Street Shelter Three	Page 7
The V Shelter	Page 8
Bespoke Shelters	Page 9



Welcome

Improving cycling facilities



Hello and welcome to Cyclepods Shelters (2012 VI Edition) We hope you will find it informative, easy to read and help answer any questions you may have.

Cyclepods Ltd launched in 2006 to transform and revolutionise cycle storage! Year on year, since inception, Cyclepods Ltd have designed, manufactured and supplied new innovative cycle storage solutions.

Our Values

Cyclepods is a Carbon Neutral company! This is central to our ethos and drives many of our values. After all, the end goal is to help make it easier and safer for people; young and old, to get out of cars and onto bikes and scooters.

We use re-cycled and re-cyclable materials in all of our products. We also aim to design solutions which make the installation of our products easier and less disruptive, so most of the time we don't need ground works. We are also conscious that one of the two biggest deterrents to cycling is bike theft. Therefore, we build as much security into our products as we can.

We are very proud that our Streetpod has just been approved by the UK Police sponsored "Secured by Design" and is the only cycle parking product afforded this status.

Finally, cyclists care about their bikes and often pay a lot of money for them, so we always aim that our products hold the bikes discreetly and carefully, which in turn deters over-crowding and damage to bikes.



Cyclepods
Transforming bike storage

Street Shelter One

Improving cycling facilities



The Cyclepods Street Shelter One is our most cost conscious shelter; capable of sheltering up to 10 bikes! Extension units can be added to form a larger shelter

BREEAM and CODE for SUSTAINABLE HOMES COMPLIANT

This bike shelter can help contribute towards gaining ENE8 Cycle storage credits when used in the appropriate situation, under the Code for Sustainable Homes

Specification

- ⇒ Shelter manufactured from hot dipped steel Galvanised 50 x 50 box section to BSEN ISO 1461
- ⇒ Transparent PET 4mm roof
- ⇒ Optional Transparent PET 4mm sides
- ⇒ Aluminium fixing straps
- ⇒ All fixings to be galvanised or aluminium
- ⇒ Nyloc nuts are used for safety
- ⇒ Anti climb end panels
- ⇒ No crawl under perimeters.
- ⇒ Angled roof

Installation notes -

Two ground fixing options-

Base plate fixing
Submerged fixing

Optional Extra's

Powder coating
Swing Gates
Slide Gates
Adjustable over-ground fixing feet

Prices *

Standard Galvanised Finish Shelter £1100.00
+ delivery and installation

Options

Extension unit + £1100 (caters up to a further 10 bikes)
Side panels (x2) + £250
Powder coating + £150
Swing Gates + £400
Sliding Gates + £650
Adjustable over-ground fixing feet + £50

All Prices + VAT

* Correct at time of print, subject to change without prior notice

Cyclepods Ltd | T - 0845 094 0490 | F - 0845 094 0151 | www.cyclepods.co.uk | info@cyclepods.co.uk



Design may vary from image shown

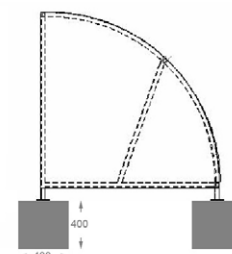
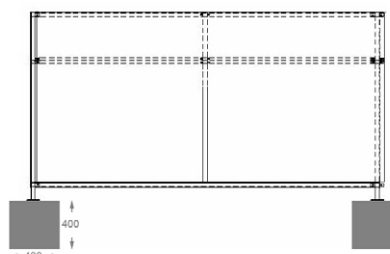
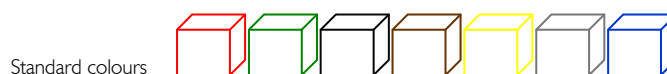
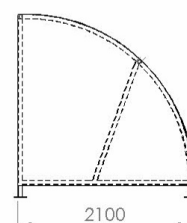
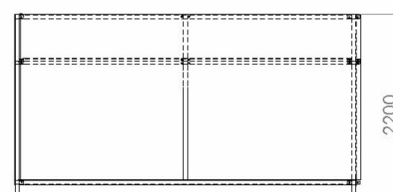
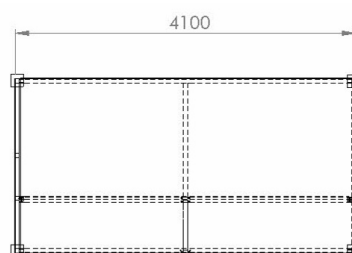

Recommend footings for submerged fix



Cyclepods
Transforming bike storage

Street Shelter One Compound

Improving cycling facilities



The Cyclepods Street Shelter One Compound is a secure facility for bikes with the ability to add extension units to suit most spaces

BREEAM and CODE for SUSTAINABLE HOMES COMPLIANT

This cycle compound can help contribute towards gaining ENE8 Cycle storage credits when used in the appropriate situation, under the Code for Sustainable Homes

Specification

- ⇒ Shelter manufactured from hot dipped steel Galvanised 50 x 50 box section to BSEN ISO 1461
- ⇒ Transparent PET 4mm roof,
- ⇒ Optional Transparent PET 4mm sides
- ⇒ Aluminium fixing straps
- ⇒ All fixings to be galvanised or aluminium
- ⇒ Nyloc nuts are used for safety
- ⇒ anti climb end panels
- ⇒ No crawl under perimeters.
- ⇒ Angled roof
- ⇒ Rear security panel
- ⇒ Front security swinging gate
- ⇒ Padlock/Hasp locking mechanism

Installation notes -

Two ground fixing options-

- Base plate fixing
- Submerged fixing

Optional Extra's

- Powder coating
- Adjustable over ground fixing feet

Prices *

Standard Galvanised Finish Compound for 20 bikes £3500 + delivery and installation

Options

- Extension unit + POA
- Powder coating + £250
- Adjustable over-ground fixing feet + £150

All Prices + VAT

* Correct at time of print, subject to change without prior notice

Cyclepods Ltd | T - 0845 094 0490 | F - 0845 094 0151 | www.cyclepods.co.uk | info@cyclepods.co.uk



Below is an example of a 40 bike compound

Design may vary from image shown

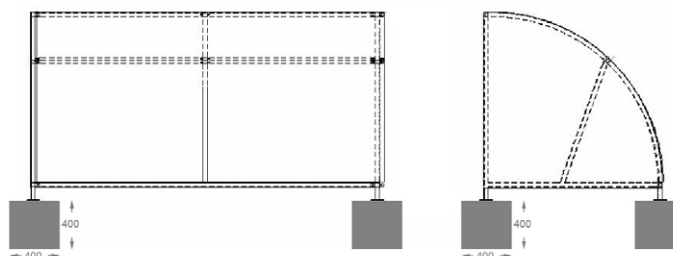
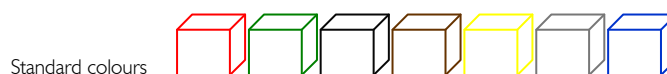
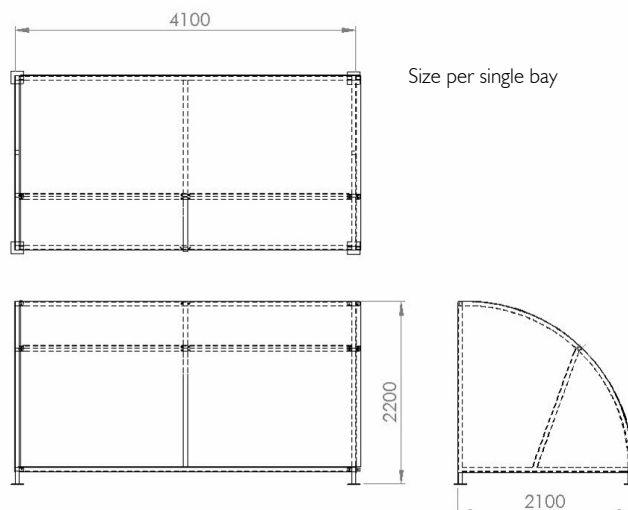

Street Shelter Two

Improving cycling facilities



The Cyclepods Street Shelter Two is a Stylish shelter perfect for new modern buildings; capable of sheltering up to 10 bikes! Extension units can be added to form a larger shelter

BREEAM and CODE for SUSTAINABLE HOMES COMPLIANT

This bike shelter can help contribute towards gaining ENE8 Cycle storage credits when used in the appropriate situation, under the Code for Sustainable Homes

Specification

- ⇒ Shelter manufactured from hot dipped steel Galvanised 50 x 50 box section to BSEN ISO 1461
- ⇒ Transparent PET 4mm roof,
- ⇒ Optional Transparent PET 4mm sides
- ⇒ Aluminium fixing straps
- ⇒ All fixings to be galvanised or aluminium
- ⇒ Nyloc nuts are used for safety
- ⇒ Angled roof



Design may vary from image shown

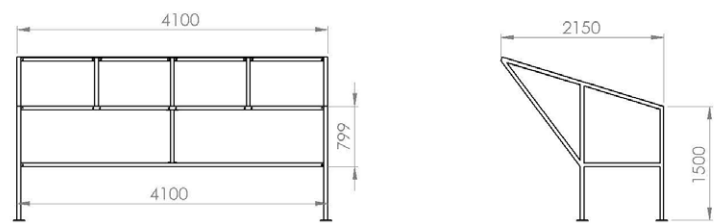

Installation notes -

Two ground fixing options-

- Base plate fixing
- Submerged fixing

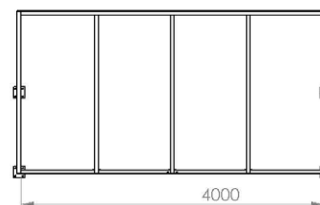

Optional Extra's

- Powder coating
- Adjustable over-ground fixing feet

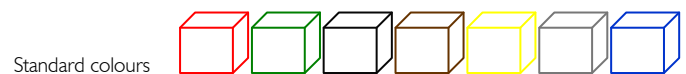

Standard colours

Prices *

Standard Galvanised Finish Shelter £1300
+ delivery and installation

Options

- Extension unit + £1300 (caters up to a further 10 bikes)
- Side panels (x2) + £200
- Powder coating + £150
- Adjustable over-ground fixing feet + £50

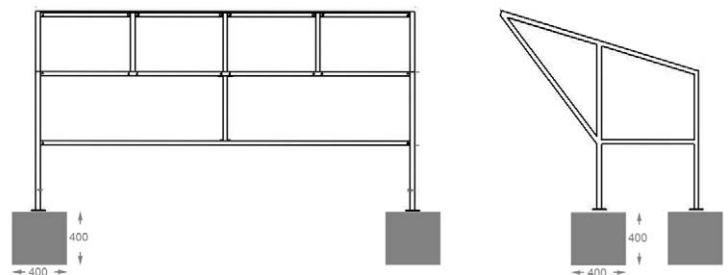

Recommend footings for submerged fix

All Prices + VAT

* Correct at time of print, subject to change without prior notice

Street Shelter Three

Improving cycling facilities



The Cyclepods Street Shelter Three is a Stylish shelter with a timeless design; capable of sheltering up to 10 bikes! Extension units can be added to form a larger shelter

BREEAM and CODE for SUSTAINABLE HOMES COMPLIANT

This bike shelter can help contribute towards gaining ENE8 Cycle storage credits when used in the appropriate situation, under the Code for Sustainable Homes

Specification

- ⇒ Shelter manufactured from hot dipped steel Galvanised
- 61 Dia hollow tube section to BSEN ISO 1461
- ⇒ Transparent PET 4mm roof,
- ⇒ Aluminium fixing straps
- ⇒ All fixings to be galvanised or aluminium
- ⇒ Nyloc nuts are used for safety
- ⇒ Angled roof

Installation notes -

Two ground fixing options-

Base plate fixing
Submerged fixing

Optional Extra's

Powder coating

Prices *

Standard Galvanised Finish Shelter £1700
+ delivery and installation

Options

Extension unit + £1600 (caters up to a further 10 bikes)
Powder coating + £150



Design may vary from image shown

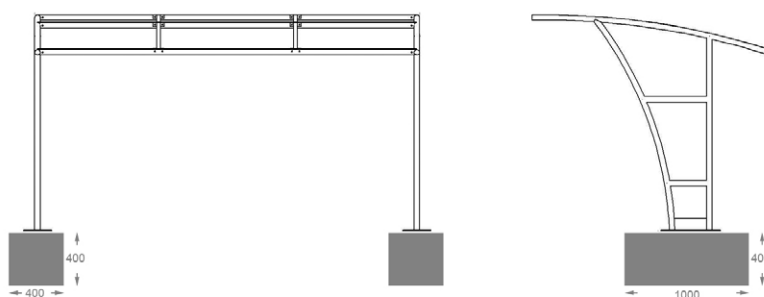
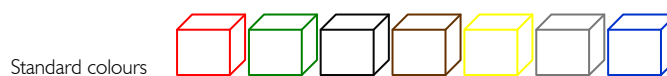
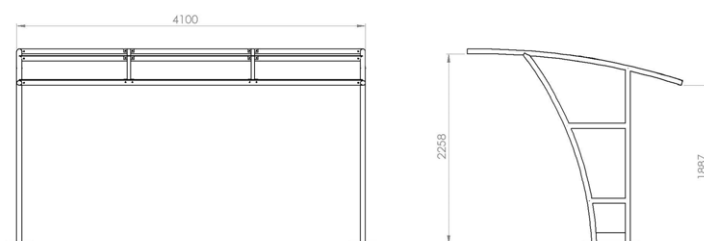

Recommend footings for submerged fix

All Prices + VAT

* Correct at time of print, subject to change without prior notice

The V Shelter

Improving cycling facilities



The Cyclepods V Shelter is a Innovative shelter with a modern design; capable of sheltering up to 10 bikes! Extension units can be added to form a larger shelter

BREEAM and CODE for SUSTAINABLE HOMES COMPLIANT

This bike shelter can help contribute towards gaining ENE8 Cycle storage credits when used in the appropriate situation, under the Code for Sustainable Homes

Specification

- ⇒ Shelter manufactured from hot dipped steel Galvanised tube section and steel plate to BSEN ISO 1461
- ⇒ Transparent PET 4mm roof,
- ⇒ Aluminium fixing straps
- ⇒ All fixings to be galvanised or aluminium
- ⇒ Nyloc nuts are used for safety
- ⇒ Angled roof
- ⇒ Integral guttering



Design may vary from image shown

Installation notes -

Two ground fixing options-

Base plate fixing
Submerged fixing

Optional Extra's

Powder coating

Prices *

Standard Galvanised Finish Shelter £2800
+ delivery and installation

Options

Extension unit + £2600 (caters up to a further 10 bikes)

Powder coating + £200

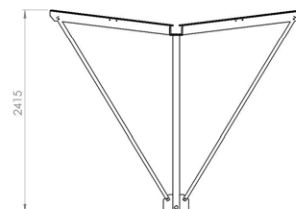
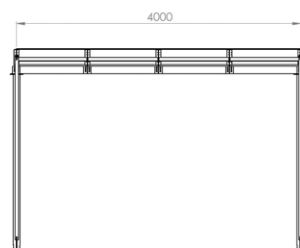
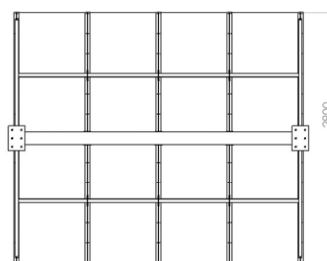

Standard colours

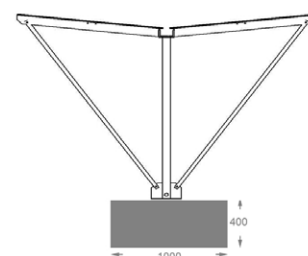
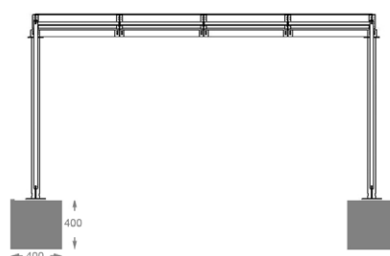
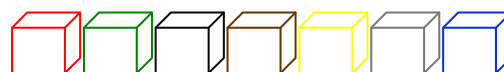

Recommend footings for submerged fix

All Prices + VAT

* Correct at time of print, subject to change without prior notice

Bespoke Service

Improving cycling facilities

The first and only Carbon Neutral Cycle Storage company

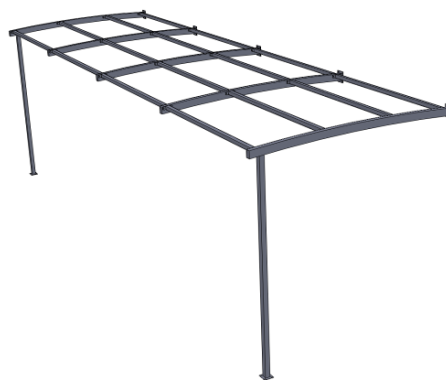
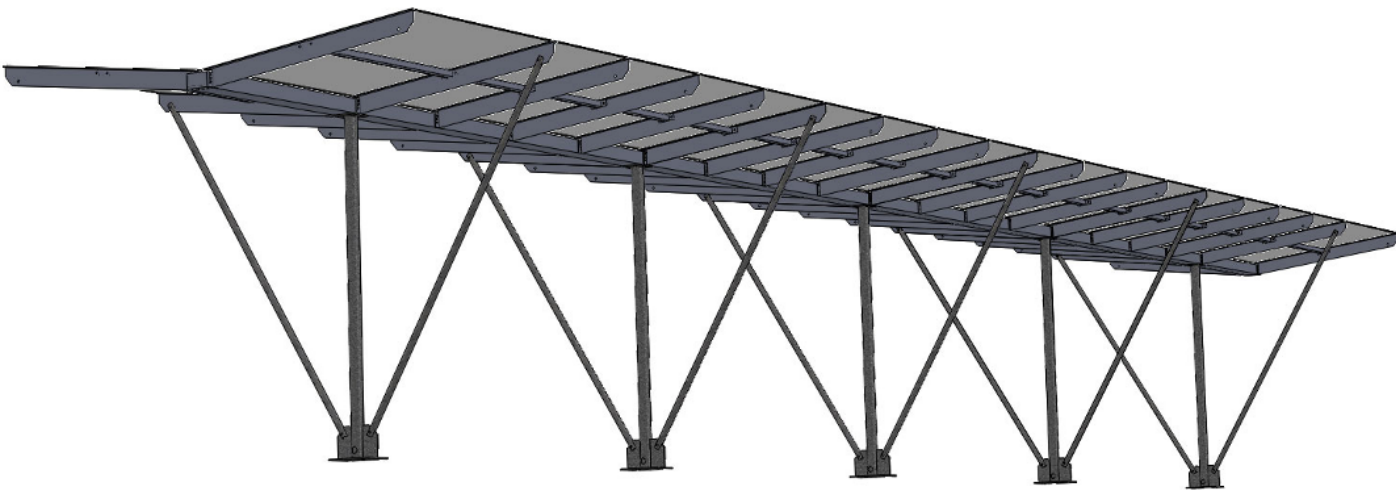
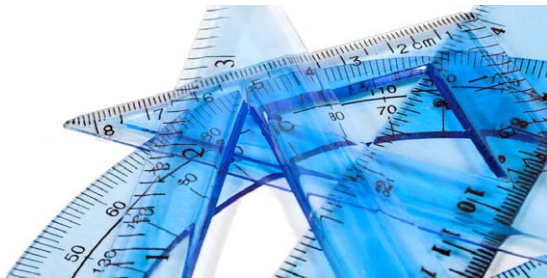

With our in-house design team, Cyclepods Ltd can offer you bespoke bicycle shelters to cater for your every requirement!

This service can be offered free to most projects and customers, taking an average of just one week for a finished design.

Due to a large back catalogue of designs we are able to offer guide prices for many and various styled shelters within a few days, therefore if you have a particular shelter style not shown in this brochure please contact us for a quick quote.

Cyclepods Ltd

5 Churchill Court
Hortons Way
Westerham
Kent
TN16 1BT

T - 0845 094 0490 | F - 0845 094 0151
www.cyclepods.co.uk | info@cyclepods.co.uk



Cyclepods
Transforming bike storage